



SRM-32 Series

32" Sunlight Readable LCD Monitor

- 1,000 Nits Brightness
- Full HD Resolution 1920 x 1080
- **TRU-Tuff** Treatment for Maximum Shock/Vibration Resistance
- Auto Re-Start After Power Loss
- Picture-In-Picture and Split-Screen
- Lockable On-Screen Display (OSD) Controls
- Can Be Customized to Meet Your Needs
- 3-Year Warranty

The SRM-32 Series Sunlight Readable HD LCD monitors are designed to operate in direct bright sunlight, or in other high ambient-light conditions. These state-of-the-art monitors produce over 1,000 nits of brightness (vs. 150-200 nits for standard laptops). This results in amazingly bright, crystal-clear HD images, even with direct, bright sunlight on the face of the screen. The SRM-32 Series Sunlight Readable monitors are ideal for use in a wide range of industrial, law enforcement, aviation, marine, military, inspection, advertising and transportation applications where viewability in direct bright sunlight is crucial.

All **TRU-Vu** industrial LCD monitors are specifically designed for use in demanding industrial, commercial, medical, and A/V applications. Every **TRU-Vu** monitor utilizes industrial-grade components and high-end LCD panels not found in retail/consumer-grade monitors. This ensures superior image quality, improved performance and greater durability.

Specifications

MODEL	SRM-32D	SRM-32E
LCD Panel	32" Color MVA Panel	
Display Resolution	1920 x 1080 (Full HD)	
Viewing Area	27.50" (W) x 15.47"(H) (698.4 x 392.85mm)	
Pixel Pitch	0.364mm x 0.364mm	
Display Colors	16.7 Million	
Aspect Ratio	16:9	
Brightness	1,000 nits	
Contrast Ratio	3,000:1	
Viewing Angle	178° (H) x 178° (V)	
Response Time	8 msec (gray to gray)	
Control	OSD (On-Screen Display) via Rear Panel Push Buttons or Remote Control	
Video Inputs	VGA, HDMI, Composite (BNC) x3	HDMI (x2), DisplayPort (x2)
Video Outputs	Composite (BNC)	
Picture-In-Picture	N/A	Standard
Split-Screen	N/A	Standard
Power Requirement	24 VDC or 90-240 VAC	90 -240 VAC
Power Consumption	100 Watts	
Enclosure	Black Powder-Coated Steel	
Mounting	Via Included Base or Rear VESA Mounting 100x100mm/200x200mm	Rear VESA Mounting 100x100mm/200x200mm
Operating Temperature	32° to 158°F (0° to +70°C)	
Shock	50 G (11 msec 1/2 sine)	
Vibration	1.5 G RMS 10-300Hz	
Dimensions	28.70" (W) x 17.04" (H) x 2.39" (D) (729 x 433 x 60.90 mm)	
Weight	32 lbs. (14.5 kg)	
Warranty	3-Years	

SRM-32 Series

32" Sunlight Readable LCD Monitor

Dimensions:

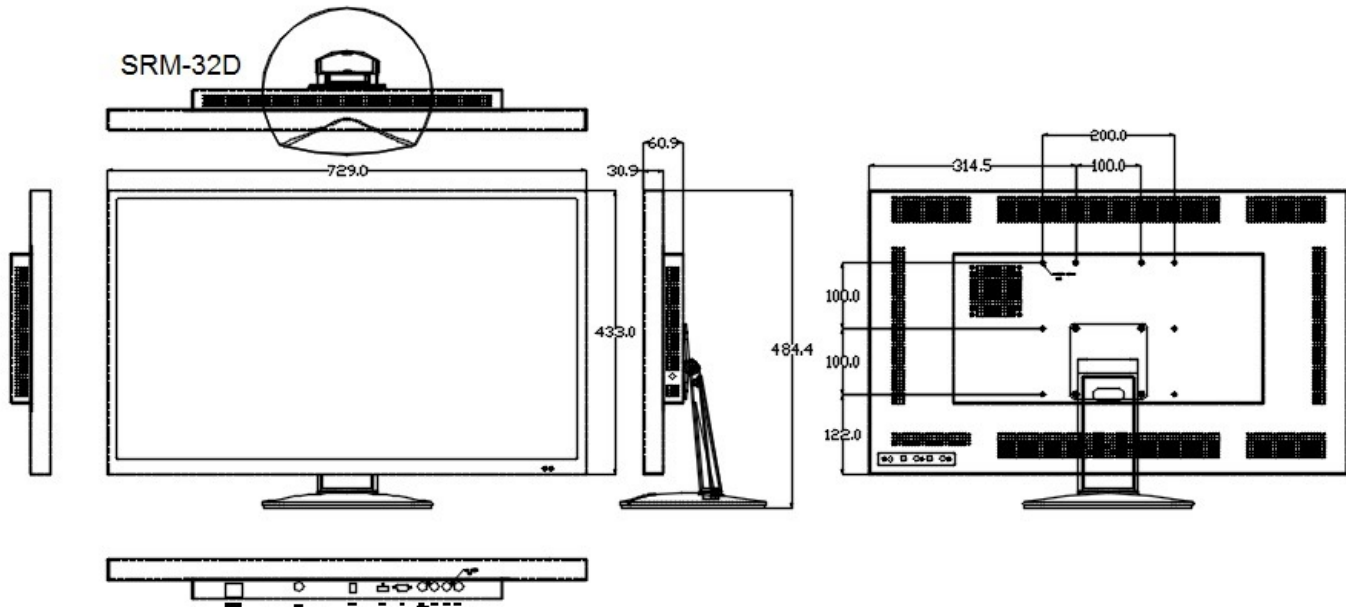

Standard Accessories:

- AC Power Cord
- Tabletop Stand (SRM-32D Only)
- VGA Cable
- 4-Pin Power Pigtail Cable (SRM-32D Only)

Available Options:

- 1,500 Nits Brightness (0° to 50° C Operating Temp.)
- Internal Speakers
- Protective/Anti-Reflective Glass
- Open-Frame Configuration
- Waterproof Enclosure
- Ambient Light Sensor
- Dim-to-Black Hotkeys
- Private Label