



MM-22C

HD Medical-Grade LCD Display

- 22" HD Medical-Grade Display
- Meets UL 60601-1 Specifications
- HD Resolution: 1680x1050
- VGA and DVI Video Inputs
- Dual Speakers
- Can Be Customized to Meet Your Needs
- 3 Year Warranty

The MM-22C is a HD Medical-Grade LCD Display, ideal for demanding surgical, medical and dental imaging applications. It meets stringent surgical requirements, and conforms to UL 60601-1. The MM-22C produces brilliant HD full color images with high contrast for excellent viewing in surgical, endoscopic and other procedures. The VESA-compliant mounting holes enable flexible mounting options such as a wall-mount, articulating arm or on a cart/stand. Backed by our 3-Year Warranty, the MM-22C provides the performance and durability required for demanding O.R., lab and clinical applications.

TRU-Vu customizable LCD monitors are specifically designed for use in demanding medical, industrial and commercial applications. Every TRU-Vu monitor utilizes industrial-grade components and high-end LCD panels not found in retail/consumer-grade monitors. This ensures superior image quality, improved performance and greater durability. Visit www.TRU-VuMonitors.com for more details.

Specifications

Specifications	
LCD Panel	22" TFT Color LCD
Resolution	1680 x 1050 (WSXGA)
Viewing Area	18.65" (H) x 11.65" (V)
Pixel Pitch	0.282 mm
Display Colors	16.7 Million
Aspect Ratio	16:10
Brightness	300 nit
Contrast Ratio	1,000:1
Viewing Angle	178° (H) x 178° (V)
Response Time	8 msec
Control	OSD (On-Screen Display)
Video Inputs	VGA, DVI
Power Requirement	90-260 VAC
Power Consumption	60 W (max)
Enclosure	ABS
Mounting	Included Base or 100mm x 100mm VESA Hole Pattern
Operating Temperature	32° to 122° F / 0° to 50° C
Humidity	5-90% RH
Approvals	UL 60601-1, UL/cUL, FCC, CE
Dimensions	20.3" (H) x 13.3" (W) x 2.4" (D) / 515.62 (H) x 337.82 (W) x 60.95 (D) mm
Weight	13 lbs. / 5.9 kg

MM-22C 22" HD Medical-Grade LCD Display

Dimensions:

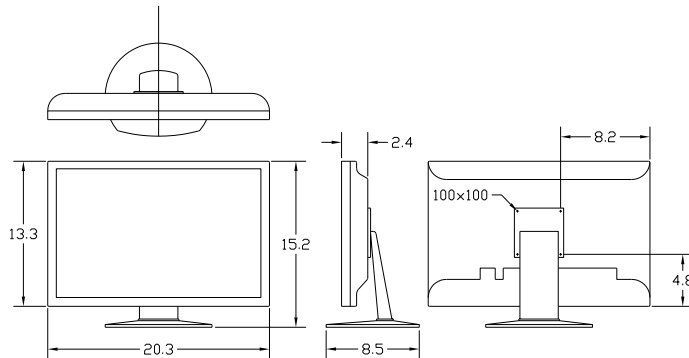

Standard Accessories:

- Green Dot Hospital-Grade Power Cord
- VGA Cable
- Tabletop Stand

Available Options:

- Private Label
- Customer Specific Modifications